

2025 EDITION
VOL. 1

FOTILE

KITCHEN APPLIANCES

COOK MORE, LOVE MORE

With FOTILE, cooking is a lot easier and happier,
the more you cook the more you love

RANGE HOOD • HOB • OVEN • MICROWAVE OVEN • STEAM OVEN •
COMBI OVEN • DISHWASHER



FOTILE X

Redefine Your Kitchen

CLOSER EXTRACTION FROM COOKING SMOKE



CLOSER EXTRACTION

Only **335mm** from the stove - almost half the distance of a traditional range hood, the FOTILE X-Series captures cooking smoke straight at the source.



WIDE SUCTION PLATE

Its **900mm-wide** suction plate intercepts cooking smoke and extracts it before it spreads.

STRONGER BRUSHLESS DIRECT-CURRENT INVERTER (BLDC)

MORE POWERFUL, BETTER EFFICIENCY

The BLDC motor uses Microchip Technology along with field-oriented (FOC) algorithm boosts maximum static pressure up to **990Pa** with an unrestrained airflow of **1930m³/h** to remove cooking smoke while keeping noise level as low as **42dB**.



FASTER COOKING SMOKE HIGHWAY

REAR EXTRACTION DESIGN

The rear extraction design allows the extraction motor to rotate 180°, actively reducing the distance of cooking smoke and extracting it in a straight path.

PATENTED NAUTILUS AIR PASSAGEWAY

Reduces wind resistance and noise. With the 3-point Extraction System, cooking smoke is collected, extracted and removed in a single uninterrupted path. **Patent No. 01132056.7**

SMARTER AIR DISTRIBUTION

INTELLIGENT AIR DISTRIBUTION

With a touch of a button, the FOTILE X-Series can **focus its extraction power** to either side of the hood.



STRONGER EXTRACTION POWER

Divert extraction power up to **70%** on either side of the hood.



HIGHER AIR PRESSURE

Increase air pressure for another **50%** on either side of the hood.

SMART SMOTION

(Smoke + Motion) Detection

Turn the hood on and off with the **wave of a hand**.

EASY TO CLEAN

All-new filter-free design with glass frame, just wipe to restore it to its original lustre.

LOW NOISE LEVEL

BLDC motor with multiple noise-reduction technologies. Noise level produced is as low as **42dB**.

Where Eastern Innovation Meets Western Elegance
Powerful Suction | Turbo Vent | Sleek Design

FOTILE Z



DOUBLE POWER SYSTEM

AUTO TURBO SYSTEM

Increase extraction power automatically when resistance is detected.

BRUSHLESS DIRECT-CURRENT INVERTER (BLDC)

Doubling extraction power by achieving air pressure up to **1140Pa** with an unrestrained airflow of **2,450m³/h**, keeping noise level as low as **40dB**. Available in range model ZMG9057

INTELLIGENT SUCTION & EXTRACTION SYSTEM

DELAY OFF TIMER

Hood will run for **2 minutes** to extract the remaining cooking smoke in your kitchen.

SMART SMOTION (SMOKE + MOTION) DETECTION

Turn the hood on and off with the **wave of hand**.

INTELLIGENT AIR MANAGEMENT

Ventilates harmful gases in the kitchen automatically to keep the kitchen air fresh.

| Air Condition | Good | Poor | Severe |
|---------------|------|--------|--------|
| Fan Speed | Off | Medium | Strong |

SPACIOUS ENTRY CAVITY



OPTIMAL COOKING SMOKE CONTROL ZONE

Only **560mm** from the stove. Fully trap cooking smoke before it starts to spread.



WIDER CHAMBER ENTRANCE

900mm wide chamber and a **415mm depth distance** distance from the wall to opened buffer plate contain the spread of your cooking smoke in a confined area.

HIGHWAY FOR COOKING SMOKE



DIRECT-FLOW SYSTEM

Leads cooking smoke from chamber entrance to exhaust in one straight line with zero to minimal obstruction.



3-STAGE VERTICAL ACCELERATION

Let cooking smoke travels easily through smoke chamber.

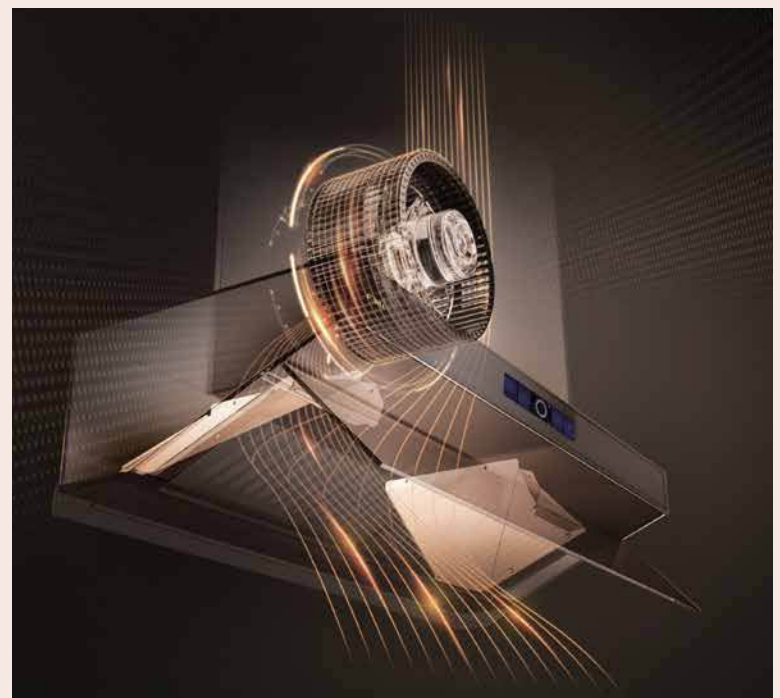

NVH TECHNOLOGY

Addresses noise, vibration and harshness from multiple angles to lower noise level to as low as **40dB**. It includes features such as BLDC motor, vibration dampers, sound-absorbing fiber cotton, bionic wing impeller and noise-reducing components.

ELEGANT DESIGN

325mm ultra-slim hood design with elegant black tempered glass perfectly matches any cabinet to define your ideal kitchen, highlighting its premium quality.

EASY TO CLEAN

Dual removeable grille filter for easy attachment and detachment when necessary.

EPS-i SERIES GAS HOB

Smart SYNC, Smart Flame



SMART SYNC

FLAMES IN, SMOKE OUT

Sync gas hob with range hood. Upon gas hob ignition, range hood automatically turns on to remove cooking smoke.

Hood-hob sync needs to be paired with FOTILE's range hood that has sync feature. Available in hob model GEG88201.



SMART FLAME

7+N ADJUSTABLE FLAME LEVELS

Easy to identify flame levels from keeping food warm or stir-fry cooking.

5.35KW HIGH FLAME POWER

From lowest **0.28kW** to **5.35kW** high flame power. More than 60% heating efficiency for optimum level of flame for fast cooking with low gas consumption.



SMART TIMER

ACCURACY GUARANTEED

180-min timer. Constant monitoring is no longer needed. It automatically turn off the fire at desired time, eliminating the chaos in the cooking process.

Available in hob model GEG88201.

NEW



EFFICIENT HEATING

REDUCE TIME CONSUMPTION BY **13.5%**

SAVE GAS CONSUMPTION BY **15%**

According to lab test result on boiling 1kg of water to 95°C by comparing EPS-i burner to other burners.

ADJUSTABLE CUT-OUT SIZE

EASY INSTALLATION

With a customizable range of 700-840 (w) x 400-480mm (d), changing your hob is much easier.

SAFETY WITH FULL PROTECTION

Auto cut-off gas for continuous cooking up to **4 hours**. *Available in hob model GEG88201.* 4-layer explosion proof panel and **12 safety features** to safeguard you and your family.

INSTANT IGNITION

FOTILE EPS-i is built for instant ignition, giving you roaring flames the moment you demand it.

FROM STEWING TO STIR-FRYING, THE EPS-I BURNER CAN DO IT



Stewing



Simmering



Boiling



Stir-Frying



Deep-Frying

0.28kW

5.35kW

More Than High Flame Power

SUPERFLAME SERIES GAS HOB



POWERFUL HEAT

5.0kW heating load, 60% heating efficiency. Powerful and fast cooking.

SAFE COOKING EXPERIENCE

12 safety features for a safer cooking experience.

STABLE PAN SUPPORT

Stable flames. Stable pan support to hold the wok.

DURABLE AGAINST RUST

High-Quality Aluminium Alloy burner, long lasting and durable against rust.

FAST IGNITION

0-second ignition with fast ignition feature.

SAVE GAS CONSUMPTION

60% heating efficiency, saves 20% on gas consumption.



6 CORE TECHNOLOGIES



Pressure-stable pre-mixing chamber.



Large flame hole.



U5-balanced direct injection chamber.



Oxygen augmenting fire cap.



Oxygen supplementation channel.



Double-stabilized flame ring.

ADJUSTABLE CUT-OUT SIZE

Easy Installation

Say hello to FOTILE Super Flame's adjustable cut-out size. FOTILE Super Flame makes it easy for any family in home to make change.

PAN SUPPORT

Thoughtfully Stable

With a pan support diameter of 165mm, FOTILE Super Flame's ultra-stable wok support is tailor-made for classic Southeast Asian sharp-bottomed wok, giving your cooking experience an extra dash of safety.

INSTANT IGNITION

Typical gas hobs require you to press the ignition for a relatively long time, and more often than not, the fire goes out right as you release the button. To that, we say no more, FOTILE Super Flame is built for instant ignition, giving you roaring flames the moment you demand it.

VITRO CERAMIC HOB

The Most Powerful In Its Class

MAXIMUM EFFICIENCY

Lower energy consumption and less heat loss for shorter cooking time and maximum efficiency. The hob is able to reach 598°C in just 4 minutes. Energy consumption from as low as RM0.22kWh**

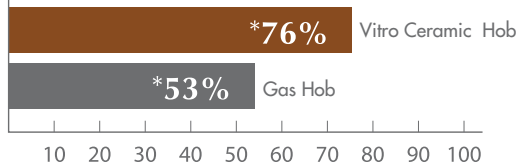

* FOTILE National Standard Lab Testing Result

**Based on current TNB tariff rate for residential usage & depending on individual household electricity consumption.

GERMAN QUALITY



SCHOTT CERAN GLASS & E.G.O. HEATING COIL
German-made SCHOTT CERAN glass and E.G.O heating coil.

TOP-NOTCH SAFETY



Digital timer, child lock, overheating protection, safety off switch and high heat indicator.



≥88%
OF HEATING
EFFICIENCY.

8
SAFETY
FEATURES

GERMAN-MADE
SCHOTT
CERAN®

3 CORE TECHNOLOGIES

4x MAGNETIC PROTECTION
More Efficient and Worry-free Cooking Experience

LARGE HEATING ZONE
For Even Heating. Copper Coil Boost Efficiency

DUAL-CORE CPU
Precise and Faster Execution

INDUCTION HOB

For A Faster and Safer Cooking Experience



REMOVABLE MAGNETIC KNOB

Operate with just a twist of knob.
Lift the knob to pause the hob.

TOP-NOTCH SAFETY



DIGITAL TIMER
Timer up to 99 mins.



STANDBY MODE
Lift the knob to pause the hob.



CHILD LOCK
Lock all buttons in the operational area.



SAFETY SWITCH OFF
Automatically switch off the hob if left idle for 2 hours.



HIGH HEAT INDICATOR
When surface temperature more than 55°C.



OVERHEATING PROTECTION
Shut down if pot dries up and temperature goes above 250°C.



POT DETECTION
After burner heats up and no pans are in its place, it will shut down the appliances after 1 minute.



OVERHEATING PREVENTION
Lower power level to 300W for 1 minute if temperature reach 120°C within 30 sec.

A Baking Good Time For The Family

REX

MASTER Series

OVEN



ACCURATE TEMPERATURE CONTROL



Ensure that your food is baked evenly. Say goodbye to unstable temperatures and half-cooked meals!

70L LARGE CAPACITY



Size matters! Bake food of all shapes and sizes effortlessly with the oven's 70L capacity and 5-layer side rack.



ENVIRONMENT FRIENDLY



LOW-E GLASS

The safe-to-be-touched double Low E-glass door prevents heat loss by keeping the surface of the door below 45°C.
(Applicable for oven model KSG7003AT & KSS7002A)

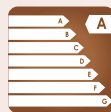

ENERGY SAVING

A-level energy efficiency.

HUMANIZED DESIGN

BEGINNER FRIENDLY

Create a variety of delicious flavours with our Easy Tips.
(Applicable for oven model KSG7003AT & KSG7007A)

OVERSIZED WINDOW

Ultra-large window provides a clear view of the baking area.

DAMPING HINGE

Allows the door to be stopped and stay balanced at any angle.
(Applicable for oven model KSG7003AT & KSS7002A)

ANTI-SPILL GRILL

Enable the grill to be balanced perfectly for increased safety.

USER-FRIENDLY

3-simple steps to operate the oven.

STEAM OVEN Cooks Healthy and Delicious Meals For Your Family

FAST HEATING

LARGE HEATING PLATE DIAMETER

Dual heating tube spiral distributor for increasing power and rapid temperature rise.

PRESERVES FOOD NUTRITIONS

100% steam heating technology retains more nutrients of your food.

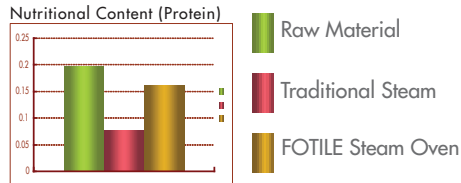

8 PRESET STEAM PROGRAMS

Experience hassle-free cooking with 8 automatic preset programs.

EVEN HEATING



By placing the steam inlet at the centre of the back cavity, the steam flows upwards and downwards throughout the whole oven, allowing even heating of food in the upper and lower layers of the oven.

MULTI-LEVEL COOKING

DYNAMIC BALANCE SYSTEM

Multi-level cooking is also possible with 3 separate shelves. This technology prevents mixing of different tastes from foods on different shelves. It also recirculates the steam to save water.



1° DEGREE PRECISE TEMPERATURE CONTROL

Having a temperature deviation that do not exceed 1° a key factor for delicious meals.

EASY TO CLEAN

Upgraded to dry heating plate, hence reducing the water accumulated at the bottom plate and easier to clean.



MICROWAVE OVEN

Heats Up A Variety of Food Instantly

COOKED TO PERFECTION

MICROWAVE AND LIGHT WAVE HEATING SYSTEMS

Whether it is the microwaving mode, light wave heating mode or even both at the same time, you can now enjoy a more efficient way of cooking.

HASSLE-FREE SOLUTION

INDEPENDENT VENTILATION

Discharges hot air from its front panel and cooking components to maximize their functions and prolong the lifespan. Oven can be directly built in without the hassle of having ventilation outlets built on the cabinet.



THOUGHTFULLY DESIGNED



8 INSTANT COOKING MENUS

Experience hassle-free cooking with 8 automatic menus.



SAFETY LOCK

Security function created especially for families with children.



3 AUTO-DEFROST FUNCTIONS

Defrost various foods.

FLATBED MICROWAVE

(Applicable to microwave oven model HW25800P-C2T)

- EVEN HEATING

Send heat at many angles. Cook food more evenly.

- LARGE COOKING SURFACE

Covers the entire bottom of cavity. Fits more food as it utilizes the capacity.

- EASY TO CLEAN

Cleaning with just a wipe. Makes cleaning quicker and easier.



One For All, All at Once **COMBI OVEN**

NEW



STEAM-BAKE SMART COMBO

Steam and bake functions at the same time. Users can bake and steam food without being limited by sequential processes.

**This function offers to P50-52 preset menu only.*

MULTILAYER COOKING

Simultaneously steam or bake multiple food at once. Easy to prepare meals for a family gathering, special occasions, or simply when batch cooking for the week.

- STEAM

4 STEAMING FUNCTIONS - LOW, NORMAL, HIGH, MULTI-LAYER STEAM

Low steam of temperature as low as 30 °C to high steam with temperature up to 120 °C. Powerful steam generated in just 50s.

DYNAMIC STEAM BALANCED TECHNOLOGY

Ensure fresh steam supply and preserves the taste of your food.

- BAKING

10 BAKING MODES

- Up Down
- Full Convection
- Steam Bake
- Multi Bake
- Convection
- Grill
- Pizza
- Broil
- Eco Bake
- 3D Grill

UNIFORM TEMPERATURE

Ensures that your food is baked evenly. Say goodbye to unstable temperature.

STEAM-BAKE - LOW, MEDIUM, HIGH HUMIDITY

Able to choose the level of moisture for your food. Retains the moisture of your food during baking.

AUTO HUMIDITY TECHNOLOGY SYSTEM

Intelligently control top and back fan - **1000r/min (top fan) + 1900r/min (back fan)** to maintain the most appropriate humidity in the cavity, ensuring the best cooking effect.

AIR-FRYING

OIL-FREE COOKING

Fat removal rate up to **98%**. Dual fan high speed rotation with high temperature to remove excessive fat of your food, making your food crispier.

DIAMOND BLUE ENAMEL COATING

Improved resistance to acid and alkaline, oil resistance, durable and easy to clean.

DEHYDRATING

PREVENTS OXIDATION OF FOOD

Dual fan high speed rotation with low temperature to prevent oxidation of food.

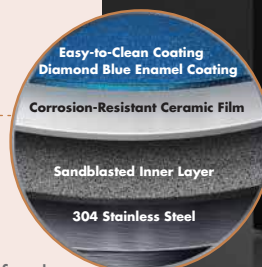

EASY TO CLEAN

- **DESCALE**
Deep cleans the oven's chamber.
- **HIGH TEMPERATURE STEAM CLEAN**
at 100°C for 10 minutes.
- **DRY VENTILATION**
Drying the chamber.
- **DEODOR**
Cavity deodorization.

HUMANIZED DESIGN

- **3 LAYER GLASS WITH LOW-E**
keep the door surface safe to touch during operation.
- **55 PRESET MENU**
to cater all your cooking needs.
- **72L CAPACITY**
Cook food of all shapes and sizes effortlessly.

PROOF FUNCTION & KEEP WARM FUNCTION

Ferments dough with shorter time using 'Proof' function. You can also keep your food warm and defrost using 'Keep Warm' function too.

DEFROST FUNCTION

Rapid thawing of frozen food.

DISHWASHER



ZERO DIRT



HIGH PRESSURE HYDROJET TECHNOLOGY

Hundreds of billions of cavitation bubbles are continuously generated in water, accelerating the speed and momentum of the water flow to remove stubborn stains effectively. Inspired by the cleaning technology of the bottom of a submarine.

Patent No. 202211216010.X & 202010288660.X



BRUSHLESS DIRECT-CURRENT INVERTER (BLDC)

Provide a maximum **40,000 Pa** strong water pressure and adjusts according to different wash settings to provide a stable and powerful wash.



ALL-CLEAN INTELLIGENT CLEANING SYSTEM

2 main spray arms + 2 supporting spray arms at the back of the chamber enhance cleaning effect by forming a 4-layer enveloping spray, alongside with 37 larger spray holes for a wider coverage to clean dishes.

ZERO ODOUR



AUTOMATED DRAINAGE SYSTEM

Water drainage is tilted for 15° and automatically closes its valve after washing to prevent backflow of sewage, keeping dishwasher odourless and clean.

Patent No. 202023337590.7



ZERO-DIRT



ZERO-ODOUR



ZERO-WORRY



ZERO-WASTE



ZERO WORRY

Dual ventilation drying distributes heat evenly and effectively. Eliminates **99.99%** of harmful bacteria under high temperature of **75°C**.

Patent No. 202121479074.X

ZERO WASTE

SMART SPACE MANAGEMENT SYSTEM

It expands a partition and divide the chamber into upper and lower layer. Saves your water, time and energy consumption.

Patent No. 202010664979.8



STORAGE FUNCTION

Automatic ventilation to store your dishes after cleaning up to **96 hours**.

SILENCE+ TECHNOLOGY

Noise level of only **42dB**.

AUTO MODE

Automatically detect the dirtiness level of your dishes to run the ideal cleaning program.

INNOVATIVE DESIGN

- **AUTO-CLEAN PROGRAM**
Keeping dishwasher cavity clean and odourless.
- **6 CORE + 4 ADDITIONAL PROGRAMS**
to cater all of your needs.
- **ADJUSTABLE HEIGHT**
Adjustable height of 30mm to suit various cabinet height for a worry-free installation.

HUMANIZED DESIGN

- **PERFECT FOR FAMILY**
Fits up to 94 tablewares.
- **MEMORY CLEANING**
Panel displays the previous cleaning mode, no need to reset everytime.
- **EXTERNAL VENTILATION**
Prevent cabinet from getting moldy by releasing hot air externally.

Beyond Clean

Your All-in-One Clean, Dry, Sterilize, Store Solution!



ALL-CLEAN INTELLIGENT CLEANING SYSTEM

High Pressure HydroJet Technology 3.0 + Orbit System Spray Arms

Effectively reaching, and cleansing the most challenging spots within your dishwasher.

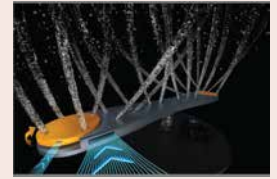

TRIO VENTILATION DRYING

Dual hot air + 1 ambient air ventilation drying distributes heat evenly and effectively.



100°C STEAM STERILIZATION

Eliminates 99.9999% of harmful bacteria.

168 HOURS STORAGE

SMART DESIGN

- Knock Twice to Open

Simply give the door two quick knocks, and watch as it glides open effortlessly, granting you easy access to its interior.

- AutoDose+, Automatic Detergent Dispensing System

The liquid and rinse aid dispenser holds sufficient detergent for 15 washes.



- Smart Projection

Display the remaining time of the washing cycle. The projection light will only begin displaying the countdown once the door is securely closed and running.

INNOVATIVE DESIGN

6 + 6
Programs

6 CORE + 6 ADDITIONAL PROGRAMS
To cater all your needs.



LOW NOISE LEVEL
As low as 40 dB.



AUTO-CLEAN PROGRAM
Keeping dishwasher cavity clean and odourless.

AUTO MODE
Automatically detect the dirtiness level of your dishes to run the ideal cleaning program.

FLEXIBLE RACK ARRANGEMENT

Both upper and lower levels of dish racks offer dedicated spaces, accommodating larger items while providing designated areas for small utensils and specialized sections for irregular items like knives and spatulas.



FOTILE 3-IN-1 SINK DISHWASHER

THE World's 1ST 3-In-1 Sink Dishwasher

HIGH PRESSURE HYDROJET TECHNOLOGY

Hundreds of billions of cavitation bubbles are continuously generated in water, accelerating the speed and momentum of the water flow to remove stubborn stains effectively. Inspired by the cleaning technology of the bottom of a submarine.

Patent No. 202211216010.X & 202010288660.X

BLDC BRUSHLESS DIRECT-CURRENT INVERTER

Provide a maximum **40,000 Pa** strong water pressure and adjusts according to different wash settings to provide a stable and powerful wash.

ALL-CLEAN INTELLIGENT CLEANING SYSTEM

360° CLEANING WITH NO BLIND SPOTS

FOTILE's sink dishwasher rotary spray is designed create a strong water-fall-like blanket of water for a more thorough cleaning. Eliminates **99.99%** of harmful bacteria under high temperature of **75°C**.

AUTOMATED DRAINAGE SYSTEM

Water drainage is tilted for 15° and automatically closes its valve after washing to prevent backflow of sewage, keeping dishwasher odourless and clean.

Patent No. 202023337590.7



TRIPLE CONVECTION DRYING

Utilizes unique "PTC hot air + residual heat + ventilation" triple drying technology. After the washing cycle is complete, the door automatically opens, allowing hot air to blow in and accelerate drying. Internal moisture is naturally expelled, preventing it from being trapped inside the cabinet.

STORAGE FUNCTION

Automatic ventilation to store your dishes after cleaning up to **96 hours**.

PURIFIER FOR FRUITS & VEGETABLE

Remove all the harmful pesticides residues using HydroJet technology.

| | | | |
|-------------------------------|---------------------------|------------------------------|----------------------------|
| Strawberry - Delicate wash | Apple - Intensive wash | Potatoes - Intensive wash | Seafood - Standard wash |
|-------------------------------|---------------------------|------------------------------|----------------------------|

HUMANIZED DESIGN

EXTRA LARGE SINK SIZE

The sink's dimensions are 455mm (w) x 405mm (d) x 211mm (h) providing plenty of room for your large pots and pans.

PERFECT FOR FAMILY

Fits up to 55 tablewares.

SAVES SPACE

Works as a sink, fruit and vegetable purifier and dishwasher, 3-in-1 appliances, saves your kitchen space.

NO MORE BENDING DOWN

No more bending down to load dishes, the Sink Dishwasher is perfect for pregnant women and the elderly.

THE GRAND KITCHEN

Imagine a kitchen not only defined by sophisticated style and luxurious finishes, but equipped to deliver the cooking solution that caters to every Malaysian kitchen's need. Embrace this timeless luxury styled with FOTILE Rose Gold series kitchen appliances.



PACKAGES

RANGE HOOD JQG9055



- BLDC Inverter Motor
- Smart SMOTION Detection
- Black decorative cover
- Auto turbo system
- Unique magnet grease filter
- Unrestrained airflow 2000m³/h
- IEC airflow 1420m³/h
- Air pressure 1050Pa
- Noise level ≤55dB

INDUCTION HOB EIG76203



- Made-in-Germany SCHOTT CERAN® glass surface
- 4x magnetic protection
- 8 safety features
- Dual-core CPU
- Removable magnetic knob
- Boost & Keep Warm function
- 1-9 power levels
- Timer: 1-99min
- Heating load (kW): Total 3.4kW / L :3.00 R:3.00
- To be connected directly to a min. 16A circuit breaker

OVEN KSG7003AT



- Multi-function oven with 11 functions
- 5 level shelf positions with stainless steel holder
- Removeable triple glazed door with double Low E-glass
- Hot air filter and 5 Japanese heating tubes
- Damping hinge for soft closing
- Child lock function and timer
- Illuminated 'O' touch screen
- Front ventilation system
- To be connected directly to a min.15A circuit breaker
- Power: 3.2kW . Capacity 70L

STEAM OVEN SCD42-C2T



- Dual-effect steam technology, fast heating
- Illuminated 'O' touch screen
- Anti-condensation technology
- Dynamic steam balance system
- 1.4 litre water tank
- 8 preset programs
- Continuous steam for 120mins
- Power : 2200W
- Capacity 42L

MICROWAVE OVEN HW25800P-C2T



- Flatbed microwave
- Independent ventilation system
- Illuminated 'O' touch screen
- Anti-condensation technology
- Microwave and grill heating
- Child lock function
- 8 express cooking menu
- Input power : Microwave 1250W / Grill 750W
- Output power : 800W
- Capacity 25L

DISHWASHER BD2BV01



- High Pressure HydroJet Technology - 40,000Pa
- Smart Space Management System
- Automated Drainage System
- Automatic ventilation, keeps storage clean for 96 hours
- Auto clean program
- Fits 47-94 pieces of tablewares
- 6 core + 4 additional programs
- Household water pressure: 0.14MPa - 1MPa
- Dual ventilation drying . Fan dry: up to 45mins
- Dishwasher capacity 136L

**OPEN
HERE**

VERSATILE ELEGANCE KITCHEN

Max out every inch of your kitchen space with FOTILE Platinum Series kitchen appliances. Transform your kitchen space into something that functions as beautifully as it looks.

RANGE HOOD
AMG9007-i

COMBI OVEN
HZK72-H1

GAS HOB

SINK DISHWASHER
SD2F-P6

PACKAGES

RANGE HOOD **AMG9007-i**



RCP
RM5,900
RM6,000

- Smart SMOTION Detection
- BLDC Inverter Motor
- Smart air diverter
- Rear motor extraction
- Delay off function
- Unrestrained airflow 1930m³/h
- Air pressure 990Pa
- Noise level ≤46dB
- Auto turbo system
- Screen lock

GAS HOB **GEG88201**



RCP
RM2,690
RM2,770

- 88cm with 2-burner gas hob
- Patented Jet collision Technology
- Smart sync with range hood
- Smart timer up to 180-min
- 7+ adjustable frame levels
- Heating load (kW) L: 5.35 R: 5.35
- ≥ 60% heating efficiency
- Fast ignition, low battery reminder
- Safety ignition pin
- Cast iron grate with tempered glass
- Flexi cut-out size
- Removable washing up

COMBI OVEN **HZK72-H1**



RCP
RM7,880
RM7,980

- Steam, Bake, Air Fry and Dehydrate
- 3 layer glass door with Low-E
- Steam-bake smart combo
- 17 cooking modes
- 55 preset programs
- 1200ml water tank, continuous working up to 120 mins
- Superheated Steam up to 120°C
- Fermentation, keep warm, defrost
- Multilayer cooking
- 6 support modes
- Capacity 72L

MICROWAVE OVEN **HW25800K-03G**



RCP
RM2,899
RM2,999

- Independent ventilation system
- Microwave and grill heating
- Touch control
- Child lock function
- Wide LED screen display
- 8 express cooking menu
- Input power : Microwave 1350W / Grill 850W
- Output power : 800W
- Capacity 25L

SINK DISHWASHER **SD2F-P6**



RCP
RM6,599
RM6,699

- 3-in-1 sink dishwasher - Sink, Dishwasher, Fruits & Vegetable Purifier
- High Pressure HydroJet Technology - 40,000Pa
- Automated Drainage System
- Storage up to 96 hours
- Fits 55 pieces of tablewares
- Food grade 304 stainless steel sink material
- Waterproofing capacitive touch screen
- Household water pressure: 0.14MPa - 1MPa
- Triple drying technology: Fan dry: 30 mins
- Large sink size: 455mm (l) x 405mm (w) x 211mm (d)



KITCHEN DESIGN IDEAS

SCAN HERE FOR MORE IDEAS



ONE OVEN PLUS

One Oven To Cook It All

STEAM

4 STEAMING FUNCTIONS - LOW, NORMAL, HIGH, QUICK STEAM





Low steam of temperature as low as **30 °C** to high steam with temperature up to **120 °C**. Powerful steam generated in just **30s**. Quick steam assist in steaming frozen food without defrosting them. Preserves the taste and texture of your food.

DYNAMIC STEAM BALANCED TECHNOLOGY

Ensure fresh steam supply and preserves the taste of your food.

BAKING

5 BAKING MODES

| Full Convection | Convect Bake | Top Bottom | Broil | Steam Bake |
|---|---|---|---|---|
|  |  |  |  |  |
| Top + Bottom Rear + Fan | Rear + Fan | Top + Bottom | Top | Top + Rear + Fan + Steam |

DUAL TEMPERATURE CONTROL

Separately control top and bottom heating element. Temperature difference up to **30°C**. eg. Top 180°C, Bottom 150°C.

UNIFORM TEMPERATURE

Ensures that your food is baked evenly. Say goodbye to unstable temperature.

STEAM-BAKE

3 Levels of Humidity to choose. Retains the moisture of your food during baking.

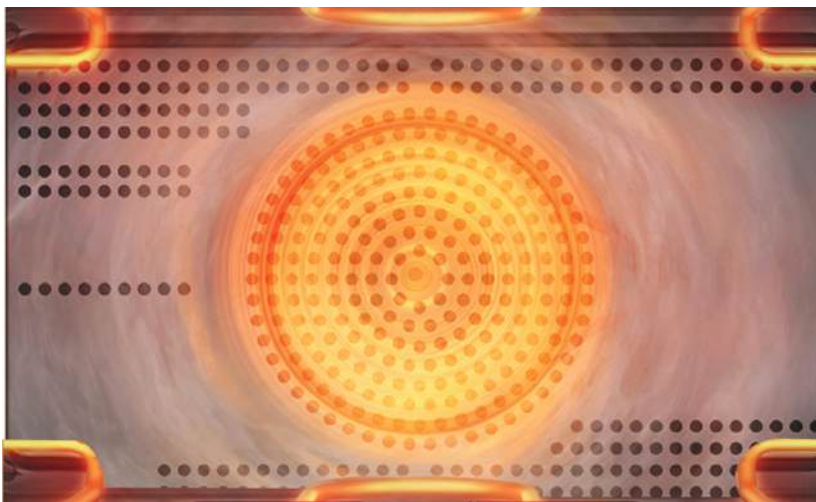

AIR-FRYING

OIL-FREE COOKING

High speed hot air rotation - **2000r/min** with **98.6%** Fat Removal Rate to remove excessive fat of your food, making your food crispier.

DEHYDRATING

PREVENTS OXIDATION OF FOOD

High Speed Rotation - **2000r/min** to prevents oxidation of food.

EASY TO CLEAN

- **DESCALE**
Descale notification will be displayed when the oven has operated up to 50 hours of steaming, to notify users to deep cleans the oven.
- **HIGH TEMPERATURE STEAM CLEAN**
at 100°C for 10 minutes.
- **DRY VENTILATION**
Drying the chamber.
- **DEODOR**
Minimize / remove the odor.
- **STERILIZATION**
Eliminates harmful bacteria up to 99.99%.

FUNCTIONS

- **JERKY FUNCTION**
Drying meat with temperature ranges from **50 - 230°C**
- **STEW FUNCTION**
Stew soup or dessert up to 4 hours.
- **PROOF FUNCTION**
Ferments dough with shorter time.
- **KEEP WARM FUNCTION**
Keep your food warm.
- **DEFROST FUNCTION**
Thaw frozen food before cooking.

HUMANIZED DESIGN

- **3 LAYER GLASS WITH LOW-E**
Keep the door surface safe to touch during operation.
- **50+6 PRESET MENU**
To cater all your cooking needs.
- **32L CAPACITY**
Cook food of all shapes and sizes effortlessly.



FOTILE X

RANGE HOOD **AMG9007-i**



RCP
WM RM5,900
EM RM6,000

- BLDC Inverter Motor
- Smart SMOTION Detection
- Smart sync
- Smart air diverter
- Rear motor extraction
- Auto turbo system
- Screen lock
- Delay off function
- Unrestrained airflow 1930m³/h
- IEC airflow 1390m³/h
- Air pressure 990Pa
- Noise level ≤46dB
- Oil Filtration Rate : 92%
- Odor Reduction Rate : 97%

FOTILE V SERIES

RANGE HOOD **JQG9009X**



RCP
WM RM5,300
EM RM5,400

- BLDC Inverter Motor
- Smart SMOTION Detection
- Smart sync
- 3-layer centrifugal filter + oil free technology
- Dual removeable grill filter
- Auto turbo system · Screen lock
- Delay off function · Memory function
- Unrestrained airflow 2100m³/h
- IEC airflow 1440m³/h
- Air pressure 1290Pa
- Noise level ≤52dB
- Oil Filtration Rate : 95%
- Odor Reduction Rate : 98%

RANGE HOOD **JQG9055**



RCP
WM RM4,200
EM RM4,300

- BLDC Inverter Motor
- Smart SMOTION Detection
- Black decorative cover
- Auto turbo system
- Unique magnet grease filter
- Screen lock
- Delay off function
- Unrestrained airflow 2000m³/h
- IEC airflow 1420m³/h
- Air pressure 1050Pa
- Noise level ≤55dB
- Oil Filtration Rate : 95%
- Odor Reduction Rate : 98.8%

RANGE HOOD **JQG9031**



RCP
WM RM3,500
EM RM3,600

- Smart SMOTION Detection
- 180-sec turbo system
- Unique magnet grease filter
- Screen lock
- Delay off function
- Unrestrained airflow 1750m³/h
- IEC airflow 1340m³/h
- Air pressure 460Pa
- Noise level ≤55dB
- Oil Filtration Rate : 95%
- Odor Reduction Rate : 98%

FOTILE Z SERIES

RANGE HOOD **ZMG9057**



RCP
WM RM4,500
EM RM4,600

- BLDC Inverter Motor · Smart Sync
- Smart SMOTION Detection
- Intelligent air management
- Dual removeable grill filter
- Auto turbo system
- Delay off function
- Unrestrained airflow 2450m³/h
- IEC airflow 1580m³/h
- Air pressure 1140Pa
- Noise level ≤48dB
- Oil Filtration Rate : 92%
- Odor Reduction Rate : 97%

RANGE HOOD **ZMG9056**



RCP
WM RM4,500
EM RM4,600

- BLDC Inverter Motor · Smart Sync
- Smart SMOTION Detection
- Intelligent air management
- Dual removeable grill filter
- Auto turbo system
- Delay off function
- Unrestrained airflow 2450m³/h
- IEC airflow 1510m³/h
- Air pressure 1170Pa
- Noise level ≤49dB
- Oil Filtration Rate : 92%
- Odor Reduction Rate : 97%

RANGE HOOD **EMG9030**



RCP
WM RM6,800
EM RM6,900

- BLDC inverter motor
- Smart Lifting System
- Intelligent air management
- Auto turbo system
- Delay off function
- Unrestrained airflow 1700m³/h
- IEC airflow 1200m³/h
- Air pressure 720Pa
- Noise level ≤48dB
- Oil Filtration Rate : 92%
- Odor Reduction Rate : 98%

RANGE HOOD **EMG9035**



RCP
WM RM4,400
EM RM4,500

- BLDC Inverter Motor
- Smart SMOTION Detection
- Patented Wing-like Surround Suction Plate
- Auto turbo system
- Screen lock · Delay off function
- Unrestrained airflow 1950m³/h
- IEC airflow 1420m³/h
- Air pressure 880Pa
- Noise level ≤48dB
- Oil Filtration Rate : 92%
- Odor Reduction Rate : 97%

FOTILE W SERIES

RANGE HOOD **EMG9037**



RCP
WM RM2,700
EM RM2,800

- Smart SMOTION Detection
- 180-sec turbo system
- Patented Wing-like Surround Suction Plate
- Rounded edge
- Delay off function
- Unrestrained airflow 1600m³/h
- IEC airflow 1240m³/h
- Air pressure 420Pa
- Noise level ≤54dB
- Oil Filtration Rate : 92%
- Odor Reduction Rate : 97%

RANGE HOOD **EMS9028S**



RCP
WM RM2,700
EM RM2,800

- Smart SMOTION Detection
- 180-sec turbo system
- Patented Wing-like Surround Suction Plate
- Rounded edge
- Delay off function
- Unrestrained airflow 1600m³/h
- IEC airflow 1210m³/h
- Air pressure 430Pa
- Noise level ≤55dB
- Oil Filtration Rate : 92%
- Odor Reduction Rate : 97%

RANGE HOOD **EMG9008-CR**



RCP
WM RM3,700
EM RM3,800

- Recirculation hood
- BLDC Inverter Motor
- Smart SMOTION Detection
- Oil filtration rate 96%
- Patented Wing-like Surround Suction Plate
- Carbon filter with 10.5mm buffer space with outer aluminium filter
- Filter replacement notification after 150-450 hours · Delay off function
- Unrestrained airflow 1400m³/h
- IEC airflow 920m³/h
- Air pressure 850Pa
- Noise level ≤53dB
- Oil Filtration Rate : 96%
- Odor Reduction Rate : 98%

ISLAND HOOD

ISLAND HOOD **EA06C**



RCP
WM RM19,400
EM RM19,500

- BLDC Inverter Motor
- Smart smoke detection
- Intelligent air management
- Auto turbo system
- Screen lock · Dual side control panel
- 4 stages ambient lights
- 1090mm extra-wide buffer plate
- Unrestrained airflow 1500m³/h
- IEC airflow 1140m³/h
- Air pressure 810Pa
- Noise level 41dB
- Oil Filtration Rate : 92%
- Odor Reduction Rate : 97%



WHAT IS IEC?

It is an international standard and conformity assessment body for all fields of electronics standard, cooker hood airflow should have this standard number (IEC 61591)

EPS-i SERIES

GAS HOB GEG88201



RCP
WM RM2,690
EM RM2,770

- 88cm with 2-burner gas hob
- Patented Jet Collision Technology
- Smart sync with range hood
- Smart timer up to 180-min
- 7+n adjustable flame levels
- Heating load (kW): L:5.35 R:5.35
- ≥60% heating efficiency
- Flexi cut-out size
- Safety ignition pin
- Flame Failure Device (FFD)
- Cast iron grate with tempered glass
- Fast ignition
- Low battery indicator
- Removable washing cup

GAS HOB GEG88306



RCP
WM RM2,890
EM RM2,970

- 88cm with 3-burner gas hob
- Patented Jet Collision Technology
- 7+n adjustable flame levels
- Heating load (kW): L:5.35 M: 1.70 R:5.35
- ≥60% heating efficiency
- Flexi cut-out size
- Safety ignition pin
- Flame Failure Device (FFD)
- Cast iron grate with tempered glass
- Fast ignition
- Low battery reminder
- Removable washing cup

TR-RINGS SERIES

GAS HOB GL536503



RCP
WM RM5,400
EM RM5,500

- 91cm with 5-burner gas hob
- Tri-rings Flame
- Top air intake
- Heating load (kW): LR:1.6 LF:3.4 C:5 RR:0.7 RF:3.4
- Brass material burner
- Safety ignition pin
- Flame Failure Device (FFD)
- 304 Stainless steel surface
- Fast ignition
- 13amp power socket

SUPER FLAME SERIES

GAS HOB GHG73201



RCP
WM RM1,370
EM RM1,450

- 73cm with 2-burner gas hob
- Heating load (kW): L:5.00 R:5.00
- ≥60% heating efficiency
- Safety ignition pin
- Flame Failure Device (FFD)
- Cast iron grate with tempered glass
- Fast ignition
- Low battery reminder
- Heat shield pan support

GAS HOB GHG78215



RCP
WM RM1,770
EM RM1,850

- 78cm with 2-burner gas hob
- Heating load (kW): L:5.00 R:5.00
- ≥60% heating efficiency
- Flexi cut-out size
- Safety ignition pin
- Flame Failure Device (FFD)
- Cast iron grate with tempered glass
- Fast ignition
- Low battery reminder
- Removable washing cup

GAS HOB GHG78312



RCP
WM RM2,070
EM RM2,150

- 78cm with 3-burner gas hob
- Heating load (kW): L:5.00 M: 1.70 R:5.00
- ≥60% heating efficiency
- Safety ignition pin
- Flame Failure Device (FFD)
- Cast iron grate with tempered glass
- Fast ignition
- Low battery reminder
- Removable washing cup

GAS HOB GHG88215



RCP
WM RM2,570
EM RM2,650

- 88cm with 2-burner gas hob
- Heating load (kW): L:5.00 R:5.00
- ≥60% heating efficiency
- Flexi cut-out size
- Safety ignition pin
- Flame Failure Device (FFD)
- Cast iron grate with tempered glass
- Fast ignition
- Low battery reminder
- Removable washing cup

ELECTRIC HOB

CERAMIC HOB EEG75201



RCP
WM RM3,970
EM RM4,050

- Made-in-Germany SCHOTT CERAN ceramic glass surface
- Made-in-Germany E.G.O electric radiation technology
- 3 heat radiation zones, 1-5 power level
- Timer: 1-599min
- Heating load (kW): Total 4.5kW
- L: 0.2 - 1 (inner ring only), 0.44 - 2.2 (inner + outer rings)
- R: 0.46 - 2.3 (inner + outer rings)
- To be connected directly to a min. 20A circuit breaker

CERAMIC HOB EEG60301



RCP
WM RM3,790
EM RM3,870

- Made-in Germany SCHOTT CERAN® ceramic glass surface
- Made-in Germany E.G.O electric radiation technology
- 4 heat radiation heating zones, 1-9 power levels
- Touch control
- Easy to clean
- Timer: 1-99min
- Heating load (kW)
- L-Upper : 1.8 L-Bottom : 1.2
- R : 2.2 Total : 5.2kW
- To be connected directly to a min. 25A circuit breaker

INDUCTION HOB EIG76203



RCP
WM RM4,370
EM RM4,450

- Made-in-Germany SCHOTT CERAN® glass surface
- 4x magnetic protection
- 8 safety features
- Dual-core CPU
- Boost & Keep Warm function
- Removable magnetic knob
- 1-9 power levels
- Timer: 1-99min
- Heating load (kW): Total 3.4kW
- L:3.00 R:3.00
- To be connected directly to a min. 16A circuit breaker



DOMINO HOB

GAS HOB D12B



RCP
WM
RM1,180
EM
RM1,260

- . 1-burner domino gas hob
- . Heating load (kW): 4.85
- . Heat efficiency ≥60%
- . Safety ignition pin
- . Flame Failure Device (FFD)
- . Cast iron grate with tempered glass
- . Low battery reminder
- . Removable washing cup

CERAMIC HOB D7RW



RCP
WM
RM1,780
EM
RM1,860

- . Made-in Germany SCHOTT CERAN® ceramic glass surface
- . Made-in Germany E.G.O electric radiation technology
- . 2 heat radiation heating zones, 1-9 power levels
- . Touch control . Easy to clean
- . Timer : 1-99min
- . Heating load (kW) : 2.4kW
- . To be connected directly to a min. 13A circuit breaker

CERAMIC HOB EEG30202



RCP
WM
RM2,450
EM
RM2,530

- . Made-in Germany SCHOTT CERAN® ceramic glass surface
- . Made-in Germany E.G.O electric radiation technology
- . 3 heat radiation heating zones, 1-9 power levels
- . Touch control . Easy to clean
- . Timer : 1-99min
- . Heating load (kW):
Upper: 1.7 ; Bottom: 1.2 ; Total: 2.9kW
- . To be connected directly to a min. 15A circuit breaker

INDUCTION HOB EIG30102



RCP
WM
RM2,350
EM
RM2,430

- . Made-in-Germany SCHOTT CERAN® glass surface
- . 4x magnetic protection
- . 7 safety features . Dual-core CPU
- . Boost & Keep Warm function
- . 1-9 power levels
- . Timer: 1-99min
- . Heating load (kW): 3.00kW
- . To be connected directly to a min. 15A circuit breaker

MORE VARIETY ON YOUR DAILY COOKING

OVEN

OVEN KSG7007A



RCP
WM
RM3,780
EM
RM3,880

- . Multi-function oven with 8 functions
- . Removeable triple glazed door with Low E-glass
- . Easy operation with mechanical control
- . 5 level shelf positions with stainless steel holder
- . Beginner friendly cooking tips
- . 3 Japanese heating tubes
- . Anti-spill grill for increased safety
- . Front ventilation system
- . Fermentation
- . Power: 2.8kW . Capacity 70L
- . To be connected directly to a min. 15A circuit breaker

OVEN KSS7002A



RCP
WM
RM4,800
EM
RM4,900

- . Multi-function oven with 11 functions
- . Removeable triple glazed door with double Low E-glass
- . LED digital display with touch control
- . 5 level shelf positions with stainless steel holder
- . Child lock function and timer
- . Damping hinge for soft closing
- . Hot air filter and 5 Japanese heating tubes
- . Front ventilation system
- . Fermentation
- . Power: 3.2kW . Capacity 70L
- . To be connected directly to a min. 15A circuit breaker

ONE OVEN

ONE OVEN HYZK26-E1



RCP
WM
RM2,999
EM
RM3,099

- . Steam, Bake, Air Fry and Dehydrate
- . 3 layer glass door with Low-E
- . Freestanding oven
- . 10 cooking modes
- . 3 cleaning modes
- . 40 preset cooking programs
- . 900ml water tank, continues working up to 96 mins
- . Superheated Steam up to 110°C
- . Fermentation, keep warm
- . Dimension W x D x H (mm):
451 x 478 x 355
- . Capacity 26L

ONE OVEN PLUS HYZK32-E3



RCP
WM
RM3,699
EM
RM3,799

- . Steam, Bake, Air Fry and Dehydrate
- . 3 layer glass door with Low-E
- . Freestanding oven
- . Dual temperature control
- . 15 cooking modes . 5 cleaning modes
- . 50+6 preset cooking programs
- . 900ml water tank, continues working up to 90 mins
- . Superheated Steam up to 120°C
- . Stew, fermentation, keep warm, defrost, sterilization, deodor
- . Dimension W x D x H (mm):
474 x 512 x 375
- . Capacity 32L

MICROWAVE OVEN

MICROWAVE OVEN HW25800K-03G



RCP
WM
RM2,899
EM
RM2,999

- . Independent ventilation system
- . Microwave and grill heating
- . Touch control
- . Child lock function
- . Wide LED screen display
- . 8 express cooking menu
- . Input power : Microwave 1350W
Grill 850W
- . Output power : 800W
- . Capacity 25L

COMBI OVEN

COMBI OVEN HZK-TS1.A



RCP
WM
RM7,580
EM
RM7,680

- . Steam, Bake, Air Fry and Dehydrate
- . 3 layer glass door with Low-E
- . Auto humidity technology system
- . 10 cooking modes . 3 cleaning modes
- . 52+3 preset programs
- . 1300ml water tank, continues working up to 90 mins
- . Superheated Steam up to 120°C
- . Fermentation, keep warm, defrost
- . Capacity 42L

COMBI OVEN HZK72-H1



RCP
WM
RM7,880
EM
RM7,980

- . Steam, Bake, Air Fry and Dehydrate
- . 3 layer glass door with Low-E
- . Auto humidity technology system
- . Steam-bake smart combo
- . Multilayer cooking
- . 17 cooking modes . 6 support modes
- . 55 preset programs
- . 1200ml water tank, continues working up to 120 mins
- . Superheated Steam up to 120°C
- . Fermentation, keep warm, defrost
- . Capacity 72L



OVEN

OVEN KSG7003AT



RCP
WM
RM5,200
EM
RM5,300

- . Multi-function oven with 11 functions
- . Illuminated 'O' touch screen
- . Removeable triple glazed door with double Low E-glass
- . LED digital display with touch control
- . 5 level shelf positions with stainless steel holder
- . Beginner friendly cooking tips
- . Child lock function and timer
- . Damping hinge for soft closing
- . Hot air filter and 5 Japanese heating tubes
- . Front ventilation system
- . Fermentation
- . Power: 3.2kW
- . Capacity 70L
- . To be connected directly to a min. 15A circuit breaker

STEAM OVEN

STEAM OVEN SCD42-C2T



RCP
WM
RM5,800
EM
RM5,900

- . Dual-effect steam technology, fast heating
- . Illuminated 'O' touch screen
- . Anti-condensation technology
- . Dynamic steam balance system
- . 1.4 litre water tank
- . 8 preset programs
- . Continuous steam for 120mins
- . Power : 2200W
- . Capacity 42L

MICROWAVE OVEN

MICROWAVE OVEN
HW25800P-C2T

RCP
WM
RM3,299
EM
RM3,399

- . Independent ventilation system
- . Illuminated 'O' touch screen
- . Microwave and grill heating
- . Child lock function
- . 8 express cooking menu
- . Input power :
Microwave - 1250W Grill - 750W
- . Output power : 800W
- . Capacity 25L

THE ZERO HERO

DISHWASHER BD3BG6



RCP
WM
RM7,588
EM
RM7,688

- . High Pressure HydroJet Technology 3.0 – 50,000Pa
- . Trio Ventilation Drying. Fan Dry: 20mins
- . 100°C Steam Sterilization
- . 168 Hours Storage System
- . Automated Drainage System
- . Knock twice to open
- . Smart projection
- . Fits 47-112 pieces of tablewares
- . 6 core + 6 additional programs
- . Household water pressure: 0.14MPa – 1MPa
- . Dishwasher Capacity 160L

DISHWASHER BD2BV01



RCP
WM
RM6,888
EM
RM6,988

- . High Pressure HydroJet Technology - 40,000Pa
- . Dual ventilation drying . Fan dry: 45mins
- . 75°C High Temperature Sterilization
- . 96 Hours Storage System
- . Smart Space Management System
- . Automated Drainage System
- . Auto clean program
- . Fits 47-94 pieces of tablewares
- . 6 core + 4 additional programs
- . Household water pressure: 0.14MPa - 1MPa
- . Dishwasher capacity 136L

DISHWASHER BD2BG5



RCP
WM
RM4,588
EM
RM4,688

- . High Pressure HydroJet Technology – 34,000Pa
- . Dual Ventilation Drying. Fan Dry: up to 45mins
- . 75°C High-temperature Sterilization
- . 96 Hours Storage System
- . Automated Drainage System
- . Fits 47-88 pieces of tablewares
- . 6 core + 3 additional programs
- . Household water pressure: 0.14MPa – 1MPa
- . Dishwasher Capacity 101L

SINK DISHWASHER SD2F-P6



RCP
WM
RM6,599
EM
RM6,699

- . 3-in-1 sink dishwasher - Sink, Dishwasher, Fruits & Vegetable Purifier
- . High Pressure HydroJet Technology - 40,000Pa
- . Triple drying technology . Fan dry: 30 mins
- . 96 Hours Storage System
- . Automated Drainage System
- . Fits 55 pieces of tablewares
- . Food grade 304 stainless steel sink material
- . Waterproofing capacitive touch screen
- . Household water pressure: 0.14MPa - 1MPa
- . Large sink size: 455mm (l) x 405mm (w) x 211mm (d)

Faucet is not included

INSTALLATION GUIDE

SINK-DISHWASHER SD2F-P6 INSTALLATION GUIDE

BEFORE INSTALLATION REQUIREMENT:

1. The outlet (drainage) pipe must be $\leq 350\text{mm}$ from the ground, pipe diameter $\geq 50\text{mm}$
2. Table top cut-out size must be ready before installation
3. Prepare a 13amp power point inside the cabinet
- ★ 4. Installation type : Top mount only

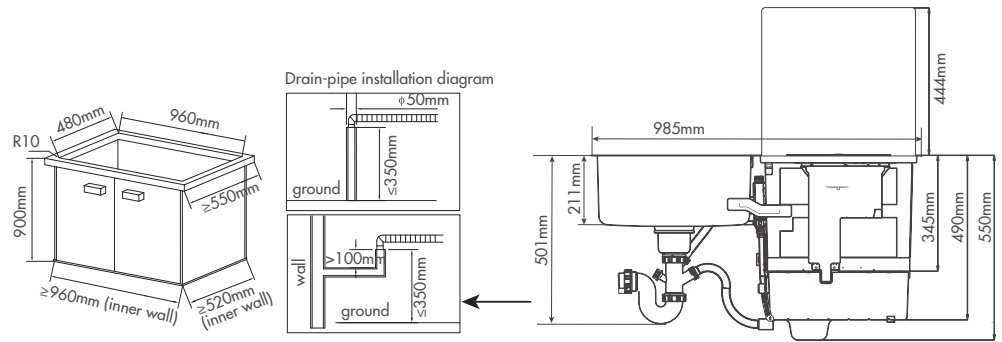

BUILT-IN DISHWASHER INSTALLATION GUIDE

BEFORE INSTALLATION REQUIREMENT:

1. The outlet (drainage) pipe & water inlet must be near to dishwasher.
2. The drain hose hook from the ground must be at least 300 mm ~ 500 mm.
3. Cabinet cut-out size must be ready before installation
4. Prepare a 13amp power point inside the cabinet.
5. Do not place any objects to block the ventilation outlet at bottom front of dishwasher.
6. If there is a base of cabinet, it must be strong enough to withstand more than 60Kg.
7. Recommended to prepare skirting board.
8. For BD3B-G6 Dishwasher, it must be installed according to the Figure 1.1

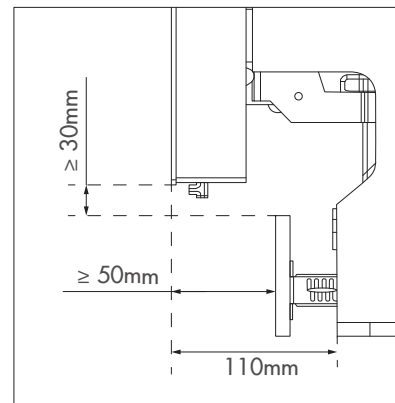
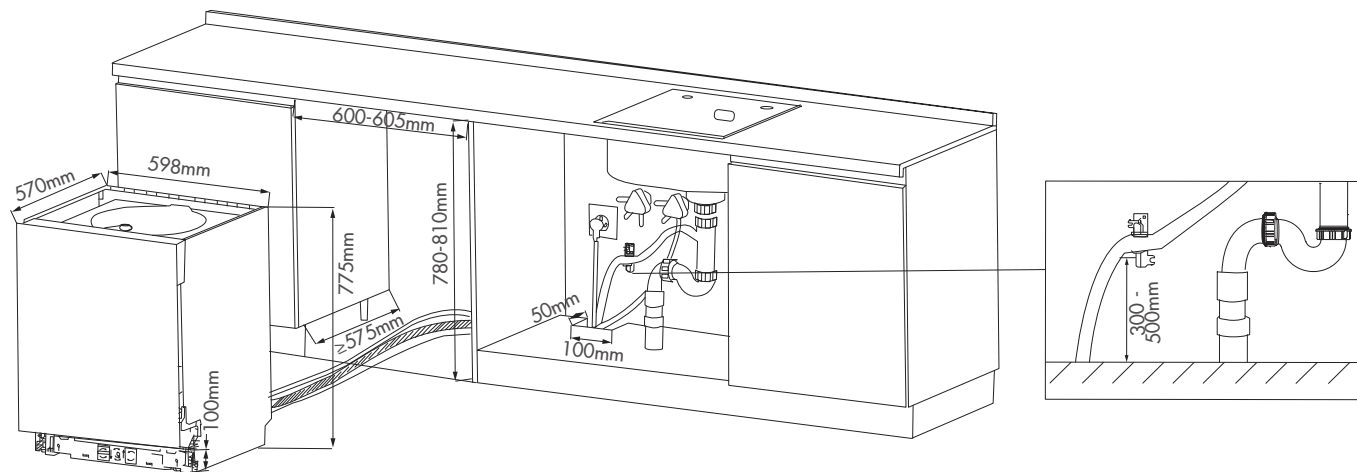
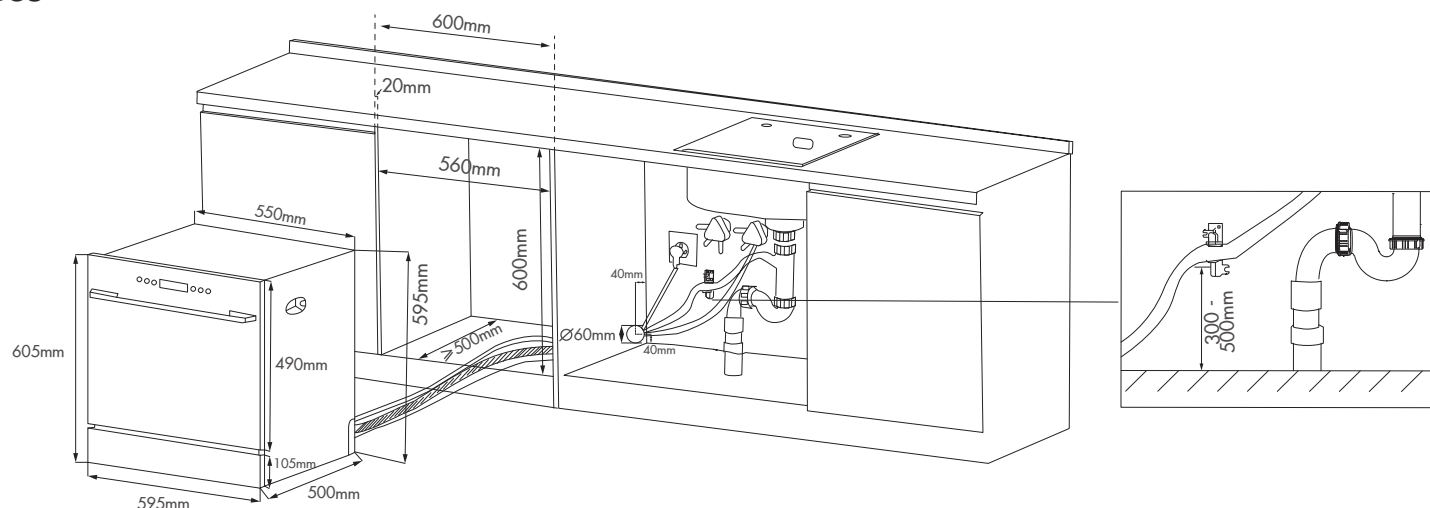

Figure 1.1

Dishwasher BD2BV01 & BD3BG6



Dishwasher BD2BG5



INSTALLATION DIAGRAM

HOOD AMG9007-i

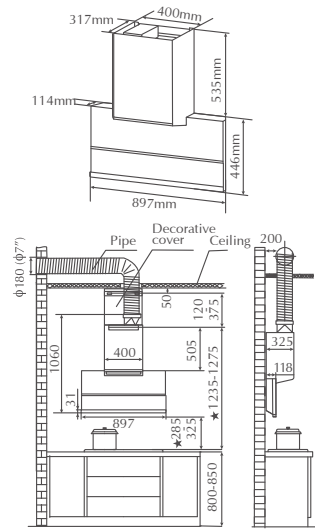

* Distance is calculated from the pan support of hob

HOOD JQG9009X

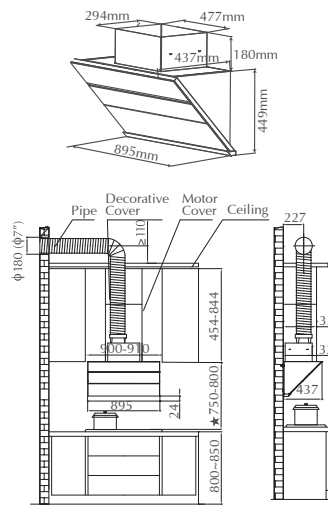

* The distance of 750mm - 800mm is calculated from pan support of hob to the hood's screw hooks.

HOOD JQG9055

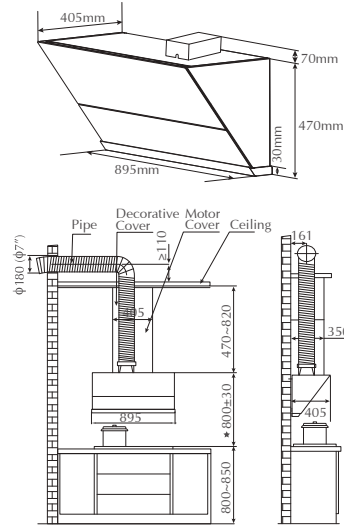

* Distance is calculated from the pan support of hob

HOOD JQG9031

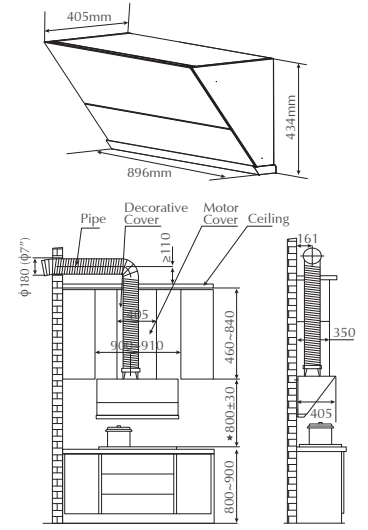

* Distance is calculated from the pan support of hob

HOOD ZMG9056 ZMG9057

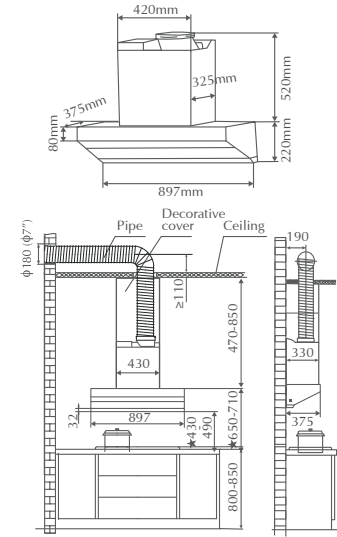

* Distance is calculated from the pan support of hob

HOOD EMG9030

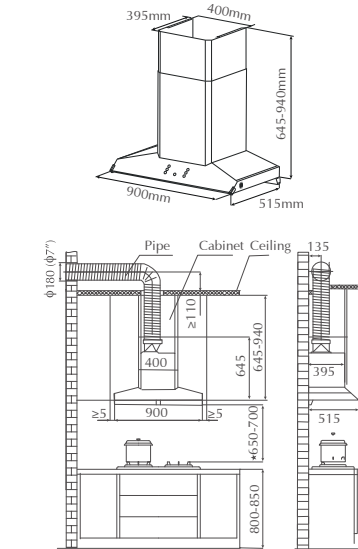

* Distance is calculated from the pan support of hob

HOOD EMG9035

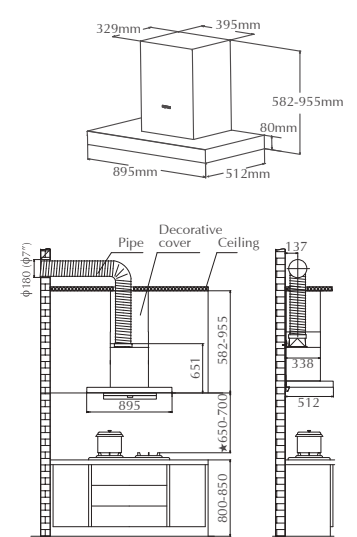

* Distance is calculated from the pan support of hob

HOOD EMG9037

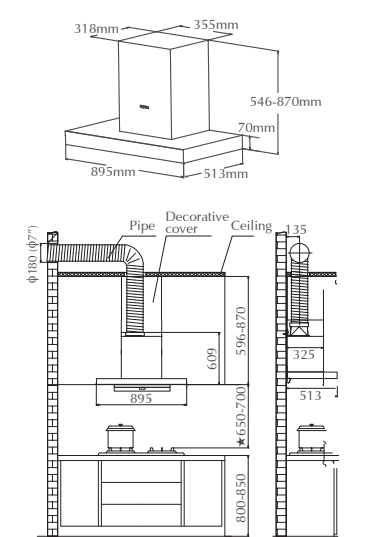

* Distance is calculated from the pan support of hob

HOOD EMS9028S

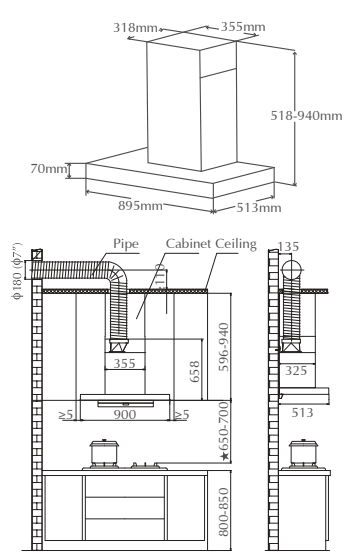

* Distance is calculated from the pan support of hob

HOOD EMG9008-CR

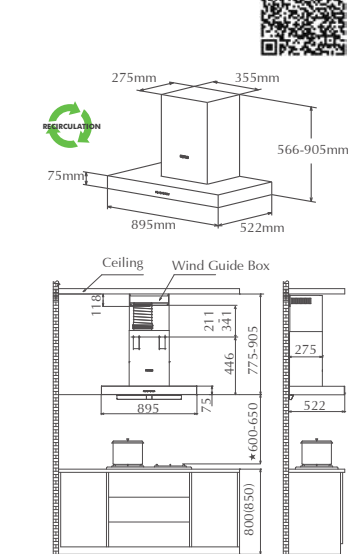

Scan here for detailed installation



ISLAND HOOD EA06C

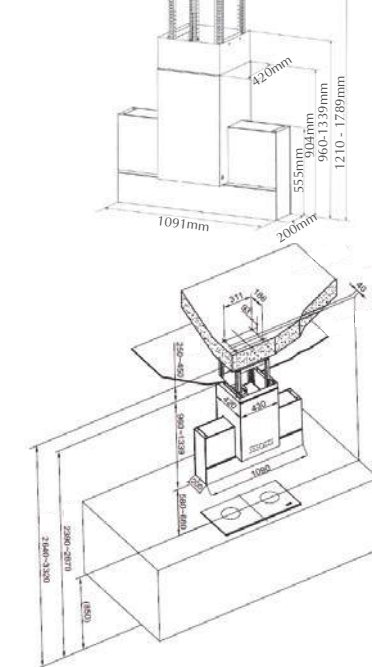

HOB GEG88201 GEG88306 GHG88215

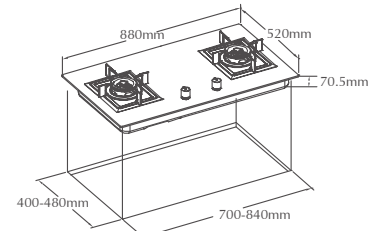

HOB GHG73201

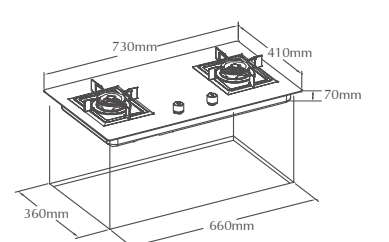

ALL FOTILE DUCTED HOOD MUST HAVE A DUCTING HOLE OPENING OF 7" / 180MM DIAMETER

*ALL UNIT MEASUREMENTS ARE IN MILLIMETERS (MM) UNLESS STATED OTHERWISE

INSTALLATION DIAGRAM

HOB
GHG78215

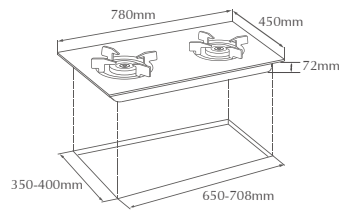

HOB
GHG78312

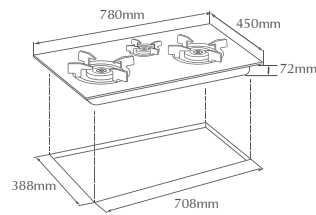

HOB
EIG76203

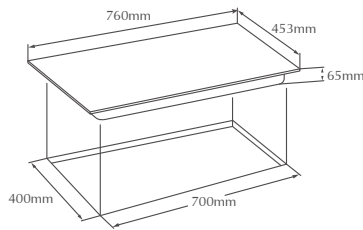

TO BE CONNECTED DIRECTLY TO A MIN. 16AMP CIRCUIT BREAKER

HOB
EEG75201

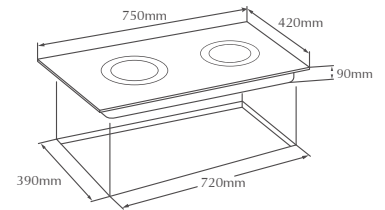

TO BE CONNECTED DIRECTLY TO A MIN. 20AMP CIRCUIT BREAKER

HOB
D12B

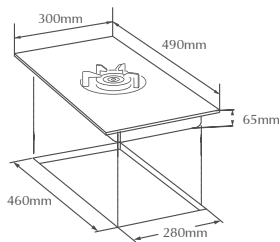

HOB
D7RW
EIG30102

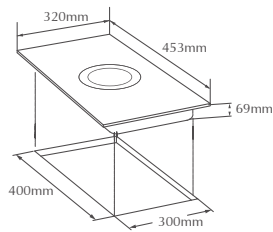

D7RW: TO BE CONNECTED DIRECTLY TO A MIN. 13AMP CIRCUIT BREAKER
EIG30102: TO BE CONNECTED DIRECTLY TO A MIN. 15AMP CIRCUIT BREAKER

HOB
EEG30202

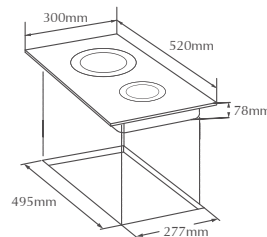

TO BE CONNECTED DIRECTLY TO A MIN. 15AMP CIRCUIT BREAKER

HOB
EEG60301

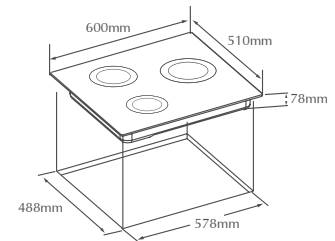

TO BE CONNECTED DIRECTLY TO A MIN. 25AMP CIRCUIT BREAKER

HOB
GLS36503

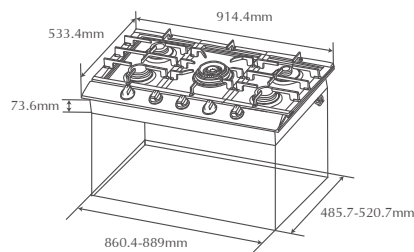

STEAM OVEN
SCD42-C2T

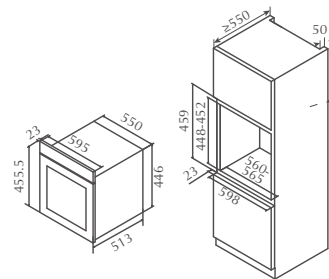

MICROWAVE OVEN
HW25800K-03G
HW25800P-C2T

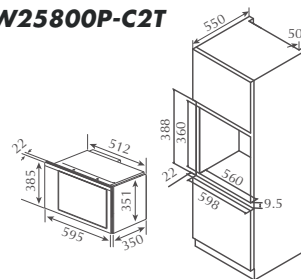

OVEN
KSG7007A
KSS7002A
KSG7003AT

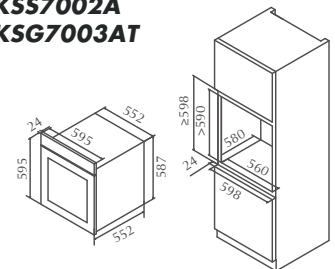

TO BE CONNECTED DIRECTLY TO A MIN. 15AMP CIRCUIT BREAKER

COMBI OVEN
HZK-TS1.A

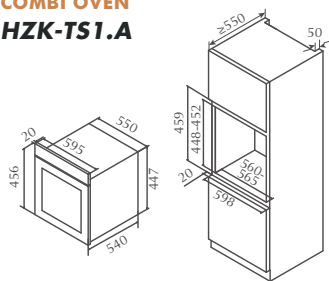

TO BE CONNECTED DIRECTLY TO A MIN. 15AMP CIRCUIT BREAKER

COMBI OVEN
HZK72-H1

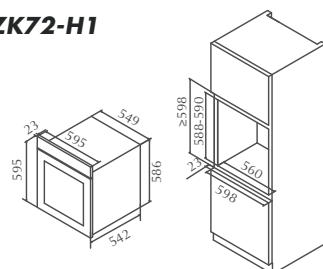

TO BE CONNECTED DIRECTLY TO A MIN. 15AMP CIRCUIT BREAKER

HOOD ACCESSORY

HONEYCOMB RECIRCULATION KIT

Available for all models except for EMG9008-CR

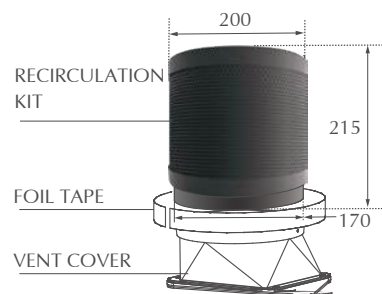

RCP

RM 198

- Oil filtration rate 96.9%
- High density activated carbon content
- 2.4x carbon mesh density with 20mm thickness
- Non-stick coating for hassle-free cleaning
- Filter replacement after 180 hours of usage
- ★ Recommended only for users that cannot do ducting in their kitchen

1. VENT COVER IS NOT INCLUDED IN THE HONEYCOMB RECIRCULATION KIT.
2. RECOMMENDED ONLY FOR USERS THAT CANNOT DO DUCTING IN THEIR KITCHEN.
3. HONEYCOMB RECIRCULATION KIT NEED TO BE CHANGE EVERY 180 HOURS.
4. RECOMMENDED TO KEEP UPPER CABINET DOOR OPEN OR ENSURE ENOUGH VENTILATION INSIDE CABINET WHEN YOU USE HONEYCOMB RECIRCULATION KIT.